

# drum washer with conveyor

Model: NormitDrum Wash



Washer is an effective solution for washing potatoes, carrots, beets, and other root vegetables, including highly dirty ones with a large amount of soil, clay and other impurities stuck to them. The process of vegetable cleaning is carried out through friction between the product and the perforated walls of the drum, or between the vegetables themselves, and also through water rinsing.



# drum washer with conveyor

## Model: NormitDrum Wash

### Three section drum

Three section drum, two different perforated and one not perforated

### Optional discharge conveyor

Drum washer can be equipped with a discharge conveyor. In production lines, it is used after a machine for preliminary washing, soaking, and separation of stones ( when processing a highly dirty product).



### Design of the equipment:

- frame, feet and drum.
- drum has a special shape for easy cleaning
- variable speed motor-gear unit with electronic frequency converter
- infeed and discharge chutes
- waste removing conveyor belt

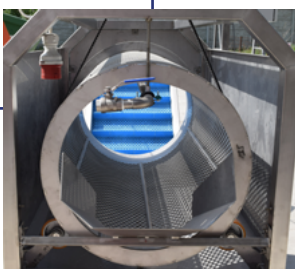

### How it works

The product is loaded into the washing machine mechanically, after processing (washing) the product is unloaded using a conveyor elevator.



# drum washer with conveyor

Model: NormitDrum Wash

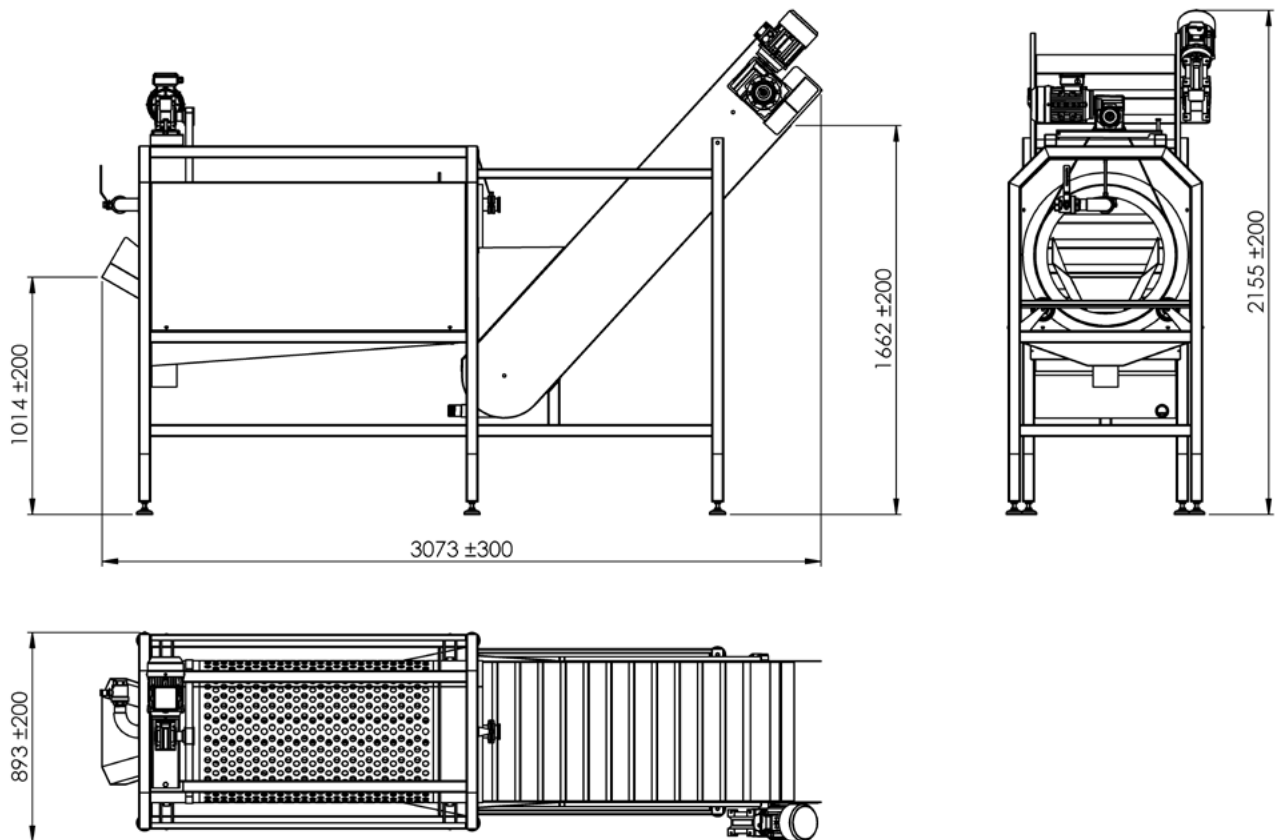

Model	Normit Drum Wash
Drum drive power, kW	1,1
Drive power of conveyor elevator, kW	0,25
Dimension (H / W / L), mm	2190/2170/850
Weight, kg	336

NORMIT FOOD, s. r. o.  
Pezinská cesta 5104  
901 01 Malacky, SLOVAKIA

Skype:  
manager.normit

Telephone number:  
+421 902 400 321

E-mail:  
sales@normit.com

Web:  
www.normit.com